

**DMO381-DMO382-DMO384**

Microwave oven



Believe in better



**Customer Care Line**  
(after sales service)

086 100 3339

**Microwave**  
Instruction manual

## CONTENTS AND PAGE NUMBER

IMPORTANT SAFETY INSTRUCTIONS	3
SPECIFICATIONS	7
EXAMINING YOUR MICROWAVE OVEN AFTER UNPACKING	7
REDUCE THE RISK OF INJURY TO PERSONS	8
EARTHING INSTALLATION	8
RADIO INTERFERENCE	9
ARCING	9
UTENSIL AND COOKWARE GUIDE	9
OVEN PARTS AND ACCESSORIES	10
COUNTERTOP INSTALLATION	11
THE CONTROL PANEL	12
OPERATING INSTRUCTIONS	12
MICROWAVE COOKING GUIDE	13
TROUBLE SHOOTING	13
CLEANING AND CARE	14
GENERAL GUIDELINES	15
MICROWAVE RECIPES	16
FREQUENTLY ASKED QUESTIONS	18
BRANCHES	19
WARRANTY	20

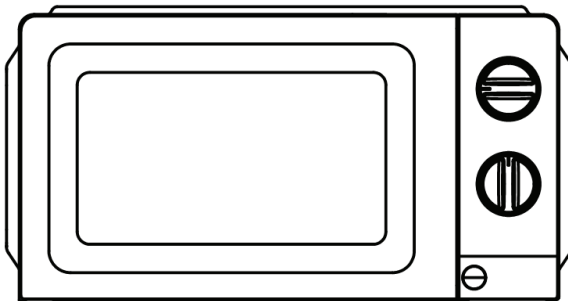



## IMPORTANT SAFETY INSTRUCTIONS

This appliance is classified as Group 2 Class B ISM. Defined as (Industrial, Scientific and Medical) equipment in which radio-frequency energy is intentionally generated and/or used in the form of electromagnetic radiation for the treatment of material, and spark erosion equipment. Class B equipment is suitable for use in domestic establishments and in establishments directly connected to a low voltage power supply network which supplies buildings used for domestic purpose.

**To reduce the risk of fire, electric shock, injury to persons or exposure to excessive microwave oven energy when using your appliance, follow basic precautions, including the following:**

- Use this appliance only for its intended use as described in this manual. This type of oven is specifically designed to heat, cook or defrost food. It is not designed for industrial or laboratory use.
- Do not use the oven for any reason other than food preparation, such as for drying clothes, paper, or any other non food items or for sterilizing purposes.
- Do not use the oven when empty, this could damage the oven.
- Do not use the cavity for storage purposes. Do not leave paper products, cooking utensils or food in the cavity when it is not in use.
- Do not operate the oven without the metal turntable tray in place. Ensure it is properly seated on the rotating base. Do not use any other Turntable in the oven. Do not operate the oven without the turntable and rotating base properly in place.
- Ensure you remove caps or lids prior to cooking when you cook food sealed in containers. Liquid or other food must not be heated in sealed containers since these are liable to explode. Pierce foods with heavy skins such as potatoes, tomatoes, whole squashes, apples and chestnuts before cooking. Unless this is done, they may burst or explode.
- Do not cook any food surrounded by a membrane, such as egg yolks, potatoes, chicken livers, etc., without first piercing them several times with a fork. Eggs in their shell and whole hardboiled eggs should not be heated in microwave ovens since they may explode, even after microwave heating has ended.

- Do not put foreign material between the oven surface and door. It could result in excessive leakage of microwave energy.
- Do not use recycled paper products for cooking. They may contain impurities which could cause sparks and/or fires when used during cooking.
- Do not pop popcorn unless popped in a microwave approved popcorn popper or unless it has been commercially packaged and is recommended especially for microwave ovens. Microwave popped corn produces a lower yield than conventional popping; there will be a number of unpopped kernels. Do not use oil unless specified by the manufacturer.
- Do not pop popcorn longer than the manufacturer's directions. (popping time is generally below 3 minutes). Longer cooking does not yield more popped corn, and may result in scorching and fire. The cooking tray may also become too hot to handle or may break.
- If smoke is emitted, switch off or unplug the appliance and keep the door closed in order to stifle any flames.
- Check the oven frequently when heating food in plastic or paper containers to avoid accidental ignition.
- The contents of feeding bottles and baby food jars must be stirred or shaken and the temperature checked before consumption in order to avoid burns.
- Always test the temperature of food or drink which has been heated in a microwave oven before you give it to somebody, especially to children or elderly people. This is important because things which have been heated in a microwave oven carry on getting hotter even though the microwave oven cooking has stopped.
- Wipe the oven interior with a soft damp cloth after each use. If you leave grease or fat anywhere in the cavity it may overheat, smoke or even catch fire when next using the oven.
- Never heat oil or fat for deep frying as you cannot control the temperature and doing so may lead to overheating and fire. Do not fry food in the oven. Hot oil can damage oven parts, utensils and can even result in skin burns.
- Read and follow the "PRECAUTIONS TO AVOID POSSIBLE EXPOSURE TO EXCESSIVE MICROWAVE ENERGY".

- Microwave heating of beverages can result in delayed eruptive boiling, therefore care must be taken when handling the container.

**To reduce the risk of injury to persons:**

- a) Do not overheat liquids.
  - b) Stir the liquid both before and halfway through heating it.
  - c) Do not use straight-sided containers with narrow necks.
  - d) After heating, allow the container to stand in the microwave oven for a short time before removing the container.
  - e) Use extreme care when inserting a spoon or other utensil into the container.
- This appliance is not intended for use by persons (including children) with reduced physical, sensory or mental capabilities, or lack of experience and knowledge, unless they have been given supervision or instruction concerning the use of the appliance by a person responsible for their safety.
  - Children must be supervised to ensure that they do not play with the appliance.
  - Only use utensils that are suitable for use in microwave ovens. Utensils should be checked to ensure that they are suitable for use in a microwave oven.
  - During use the appliance becomes hot. Care should be taken to avoid touching heating elements inside the oven.
  - Do not use a steam cleaner in the oven.
  - Remove wire twist-ties from paper or plastic bags before placing the bag in the oven.
  - Cooking utensils may become hot because heat is transferred from the heated food. Potholders may be needed to handle the utensil.
  - Do not operate this appliance if it has a damaged cord or plug, if it is not working properly or if it has been damaged or dropped. If the supply cord is damaged, it must be replaced by the manufacturer or its service agent or a similarly qualified person in order to avoid a hazard.
  - Do not use corrosive chemicals or aerosols to clean this appliance.
  - Do not operate the oven without the tray, the rotating base, and the shaft in their proper positions.

- Make sure that the power supply cord is undamaged and does not run under the oven or over any hot or sharp surface.
- The wall socket must be readily accessible so that the Microwaves plug can be easily unplugged in an emergency.
- Do not use the oven outdoors.
- Do not overcook food.



## **PRECAUTIONS TO AVOID POSSIBLE EXPOSURE TO MICROWAVE ENERGY**

### **PRECAUTIONS TO AVOID POSSIBLE EXPOSURE TO EXCESSIVE MICROWAVE ENERGY**

- Do not attempt to operate this oven with the door open since open-door operation can result in harmful exposure to microwave energy. It is important not to bypass or tamper with the safety interlocks.
- Do not place any object between the oven front face and the door or allow soil or cleaner residue to accumulate on sealing surfaces.
- Do not operate the oven if it is damaged.
- **WARNING:** If the door or door seals are damaged, the oven must not be operated until it has been repaired by a competent person : It is particularly important that the oven door closes properly and that there is no damage to the:  
Door (bent, skew or dented)  
Hinges and latches (broken or loosened)  
Door seals and sealing surfaces. (deformed or covered with dirt deposits)
- **WARNING:** It is hazardous for anyone other than a trained, competent person to carry out any service or repair operation which involves the removal of any cover which protects against exposure to microwave energy.
- **WARNING:** Liquids and other foods must not be heated in sealed containers since they are liable to explode.

## SPECIFICATIONS

Model:	DMO381-DMO382-DMO384
Rated Voltage:	230V~50Hz, 1100W (Microwave)
Rated Output Power (Microwave):	700 W
Operating Frequency	2450MHz
External Dimensions: (H x W x D)	243mm(H)×446mm(W)×332mm(D)
Oven Cavity Dimensions: (H x W x D)	202mm(H)×301mm(W)×311mm(D)
Oven Capacity	20 Litres
Net Weight:	Approx. 9.2 kg

## EXAMINING YOUR MICROWAVE OVEN AFTER UNPACKING

Unpack the oven, remove all packing material, and examine the oven for any damage such as:

- A damaged, misaligned or bent door.
- Damaged door seals and sealing surfaces.
- Broken or loose door hinges and latches.
- Dents inside the cavity or on the door.

Notify the dealer immediately if the oven is damaged. Do not install or operate the oven if it is damaged.

### Intended use

This appliance is intended to be used in household and similar applications such as:

- staff kitchen areas in shops, offices and other working environments;
- by clients in hotels, motels and other residential type environments;
- farm houses;
- bed and breakfast type environments.

### Where to place your microwave oven

Place the oven on a flat and stable surface.

Do not place the oven where heat, moisture, or high humidity are generated, or near any combustible materials.

Do not store or use this appliance outdoors.

Do not use this oven near water, in a wet basement or near a swimming pool.

The oven must have sufficient ventilation to operate correctly. See the counter installation diagram for space requirements around the microwave oven.

Do not remove the feet.

The microwave oven shall not be placed in a cabinet unless it has been tested in a cabinet.

Leave space behind and sides and upper of the oven. All air vents must have clearance. If all vents are covered during operation, the oven may overheat and, eventually, lead to oven failure.

Keep away from radio and TV sets. If the oven is located close to a TV, radio interference may result.

Keep away from heating appliances and water taps. Keep the oven away from hot air, steam or water when choosing a place to position it, or the insulation might be adversely affected and breakdowns occur.

**WARNING:** Only allow children to use the oven without supervision when adequate instructions have been given so that the child is able to use the oven in a safe way and understands the hazards of

## REDUCE THE RISK OF INJURY TO PERSONS

### DANGER

#### Electric Shock Hazard

Touching some of the internal components can cause serious personal injury or death. Do not disassemble this appliance.

### WARNING

#### Electric Shock Hazard

Improper use of the grounding can result in electric shock. Do not plug into an outlet until appliance is properly installed and grounded.

## EARTHING INSTALLATION

This appliance must be earthed. This oven is equipped with a power cord and earthed plug. It must be plugged into a wall socket that is properly installed and earthed. Refer to the rating plate for the appliance voltage and check that the voltage corresponds with the supply voltage in your home.

In the event of an electrical short circuit, earthing reduces risk of electric shock by providing an escape wire for the electric current. It is recommended that a separate circuit serving only the oven be provided. Using a high voltage power supply is dangerous and may result in a fire or other accident causing oven damage.

### WARNING

**Improper use of the earthed plug can result in a risk of electric shock. If the proper electrical connections are not made, the microwave oven may be damaged and possible injury may result. Neither the manufacturer nor the dealer can accept any liability for damage to the oven or personal injury resulting from failure to observe the electrical connection procedures.** If you have any doubts about the electrical installation or if earthing instructions are not completely understood please consult an electrician or qualified technician.

### Electrical Connection

We recommend the use of good quality plugs and wall sockets that can be switched off when the machine is not in use.

#### Power supply

Check your local power source. The voltage used must be the same as specified on this oven. Using a higher voltage may result in a fire or other accident causing oven damage. Using low voltage will result in slow cooking. We are not responsible for damage resulting from use of this oven with a voltage or ampere fuse other than those specified.

If the supply cord is damaged, it must be replaced by the manufacturer or its service agent or a similarly qualified person in order to avoid a hazard.

If it is necessary to use an extension cord, use only a 3-wire extension cord.

1. A short power-supply cord is provided to reduce the risks resulting from becoming entangled in or tripping over a longer cord.
2. If a long cord set or extension cord is used:
  - 1)The marked electrical rating of the cord set or extension cord should be at least as great as the electrical rating of the appliance.
  - 2)The extension cord must be a grounding-type 3-wire cord.
  - 3)The long cord should be arranged so that it will not drape over the counter top or tabletop where it can be pulled on by children or tripped over unintentionally.



## RADIO INTERFERENCE

Microwave ovens can cause radio and TV interference. This may be reduced or eliminated by taking the following measures:

1. Clean the door and sealing surfaces of the oven.
2. Reorient the receiving antenna of the radio or the television.
3. Relocate the microwave oven with respect to the receiver.
4. Move the microwave oven away from the receiver.
5. Plug the microwave oven into a different outlet so that the microwave oven and receiver are on different branch circuits.

## ARCING

**Arcing is the term used for sparks in the oven.**

Arcing is caused by:

1. Metal foil touching the side of the oven.
2. If foil does not follow the shape of the food, upturned edges act like antennas.
3. Metal such as twist ties, poultry pins or gold rimmed dishes.
4. Recycled paper containing small particles of metal.

## UTENSIL AND COOKWARE GUIDE

1. Glass or Pyrex dishes allow energy to pass through the utensil and heat the food.
2. Microwaves cannot penetrate metal, so don't use metal dishes or utensils. Neither use any dish which has metallic decorations or a gold-foiled pattern.
3. Do not use recycled paper products when microwave cooking as these may contain small metal fragments which may cause sparks and or fires.
4. Use round or oval dishes rather than square or oblong ones as food in corners tends to overcook.
5. Narrow strips of aluminum foil may be used to prevent overcooking of exposed areas. (on drum stick ends etc.) but keep a distance of at least 1 inch (2.54cm) between the foil and the cavity to prevent arcing.
6. Do not use metal twist ties. These may cause arcing and could cause a fire in the oven.

COOKWARE	MICROWAVE
Heat resistant glass.	Yes
Non heat resistant glass.	No
Heat resistant ceramics.	Yes
Microwave compatible plastic dishes.	Yes
Paper toweling—with caution.	Yes
Metal dishes or utensils.	No
Metal trays or racks.	No
Aluminium foil containers.	No



**Important:** Read these instructions for use carefully so as to familiarize yourself with the appliance. Keep these instructions for future reference.

## OVEN PARTS AND ACCESSORIES

Remove the oven and all materials from the carton and oven cavity.

**Your oven comes with the following accessories:**

Glass tray x 1 - Turntable ring assembly x 1 - Instruction Manual x 1

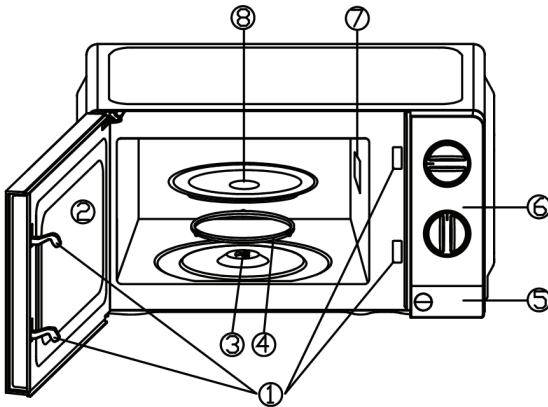

1. Door Safety Lock System
2. Oven Window
3. Shaft
4. Roller Ring
5. Door Release Button
6. Control Panel
7. Wave Guide (Please do not remove the mica plate covering the wave guide)
8. Glass Tray

### Turntable Installation

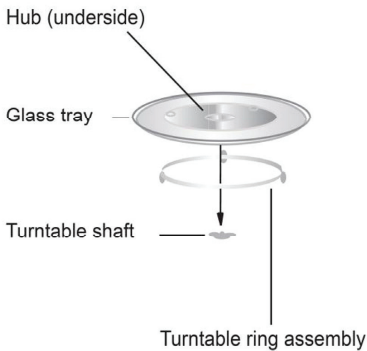

- a. Never place the glass tray upside down. The glass tray should never be restricted.
- b. Both glass tray and turntable ring assembly must always be used during cooking.
- c. All food and containers of food are always placed on the glass tray for cooking.
- d. If glass tray or turntable ring assembly cracks or breaks, contact your nearest authorized service center.

## COUNTERTOP INSTALLATION

Remove all packing material and accessories.

Examine the oven for any damage such as dents or broken door. Do not install if oven is damaged.

**Cabinet:** Remove any protective film found on the microwave oven cabinet surface.

Do not remove the light brown Mica cover that is attached to the oven cavity to protect the magnetron.

### Installation

1. Select a level surface that provides enough open space for the intake and/or outlet vents.

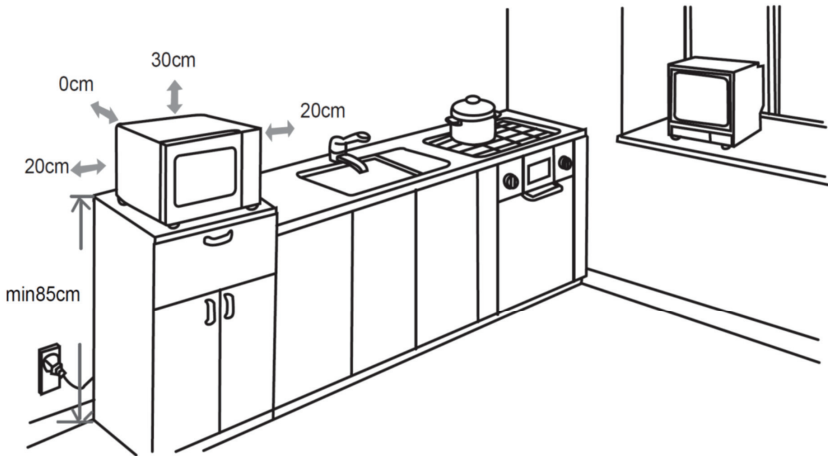

- (1) The minimum installation height is 85cm.
- (2) The rear surface of appliance shall be placed against a wall. Leave a minimum clearance of 30cm above the oven, a minimum clearance of 20cm is required between the oven and any adjacent walls.
- (3) Do not remove the feet from the bottom of the oven.
- (4) Blocking the intake and / or outlet openings can damage the oven.
- (5) Place the oven as far away from radios and TV as possible. Operation of microwave oven may cause interference to your radio or TV reception.

Plug your oven into a standard household outlet.

Be sure the voltage and the frequency is the same as the voltage and the frequency on the rating label.



**WARNING:**

Do not install oven over a range cooktop or other heat-producing appliance. If installed near or over a heat source, the oven could be damaged and the warranty would be void.



**WARNING:**

Accessible surfaces may become hot during operation.

## The control panel

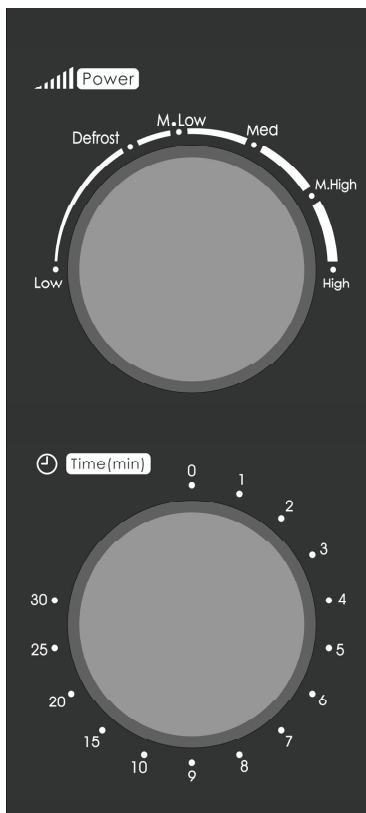

The control panel consists of two function operators. One is a timer knob, and another a power knob.

### Power/Action Selector

Use this operator knob to choose a cooking power level. It is the first step to starting a cooking session.

### Timer Knob

It offers visual timing settings at the easy turn of a thumb to select a desired cooking time of up to 30 minutes per cooking session.

### Microwave Cooking

For microwave cooking, there are six power levels from which to choose. Select a level that matches your cooking requirements.

The power level increases as the knob is turned clockwise. The power levels are classified as follows on the table below:

	Power Output	Description
1	100%	High
2	88%	M.High
3	73%	Med
4	52%	M.Low
5	42%	Defrost
6	20%	Low

## OPERATING INSTRUCTIONS

### To start a cooking session,

1. Place food in oven and close the door.
2. Turn Power Selector to select a power level.
3. Use Timer knob to set a cooking time.



**NOTE:** As soon as the timer is turned, oven starts cooking.

When selecting time for less than 2 minutes, turn timer past 2 minutes and then return to the correct time.

**CAUTION: ALWAYS RETURN TIMER BACK TO ZERO POSITION** if food is removed from the oven before the set cooking time is complete or when the oven is not in use. To stop the oven during the cooking process, push the door release button or open the door by the handle.

## MICROWAVE COOKING GUIDE

1. Place the food in a microwave approved cooking utensil and place it centrally on the glass tray. Placing a heavy load on the perimeter of the glass tray could cause the glass tray to dislodge from the rotating base. Arrange the food carefully. Place thickest areas towards outside of the cooking utensil.
2. Do not place food directly on the glass tray unless the food is self contained and will not spill. When cooking more than one item, arrange the food so that the items are evenly spaced.
3. Watch the cooking time. Cook for the minimum time indicated in the recipe and add more as needed. Food which is severely overcooked can smoke or ignite.
4. Cover foods while cooking to prevent spattering and to help the food cook evenly.
5. Turn foods over once during microwave cooking to speed up the cooking of foods such as chicken and burgers. Large items such as roasts must be turned over at least once.
6. Rearrange foods such as meatballs halfway through cooking both from the top to the bottom of the dish and from the center of the dish to the outside of the dish.
7. Do not operate the oven without the rotating base and tray in position.

## TROUBLE SHOOTING

Normal occurrences. These are not a fault.	
Microwave oven interfering with TV reception.	Radio and TV reception may be interfered with when microwave oven is operating. This is normal.
Dim oven light.	In low power microwave cooking, the oven light may become dim. This is normal.
Steam accumulating on the door, hot air out of vents.	In cooking, steam may emit from food. Most will escape from vents. However some may accumulate on cool areas like the oven door. This is normal.
Oven started accidentally with no food in it.	Do not run the microwave without any food inside. It is very dangerous.

If the oven fails to operate, please check the following before calling for service:

Problem	Possible cause	Remedy
Oven cannot be started.	1) Power cord not plugged in properly.	Unplug, then plug in again after 10 seconds.
	2) Fuse blown or circuit breaker has tripped.	Replace fuse or reset circuit breaker (repaired by professional personnel)
	3) Problem with power outlet.	Test power outlet with another electronic appliance.
Oven does not heat.	4) Door not properly closed.	Close door properly.
Glass turntable is noisy when the microwave oven operates.	5) Dirty roller rest or dirty oven bottom.	Refer to "Maintenance of microwave" to clean dirty parts.



**CAUTION Personal Injury Hazard** It is hazardous for anyone other than a competent person to carry out any service or repair operation that involves the removal of a cover which gives protection against exposure to microwave energy.

**ADDENDUM** If the apparatus is not maintained in a good state of cleanliness, its surface could be degraded and affect the lifespan of the apparatus and lead to a dangerous situation.

## CLEANING AND CARE

### INSIDE THE OVEN

**Turn off the oven and remove the power plug from the wall socket before cleaning.** Keep the inside of the oven clean. For easy cleaning, wipe spills and splatters as they occur with a damp cloth or sponge with water and a mild detergent. Avoid the use of aerosols and other harsh cleaners as these may stain, streak or dull the door surface. Rinse the cavity of any cleaning residue with a clean damp or sponge after cleaning. Dry with a soft cloth. These areas can also be cleaned by using plastic or nylon scouring pads. For hard to remove soil, use a mild non-abrasive cleaner. Use on the stainless steel areas, turntable and rotating base only. Remove odours from your oven by combining a cup of water with the juice and the skin of one lemon in a deep microwave proof bowl, microwave for 5 minutes. Wipe thoroughly and dry with a soft cloth.

#### **Warning**

Just as your traditional oven becomes hot also this oven will become hot during use of the functions.

Children should be supervised at all times when using the oven.

### **TURNTABLE AND ROTATING BASE**

These two parts are easily removable for cleaning. The turntable should be cleaned frequently. If food spills are accumulated under the rotating base, the oven will not operate efficiently. Be sure to wipe up any spills as they occur in this area. Clean these parts as described in cleaning inside of the oven. Be sure to properly reinstall these parts into the cavity after cleaning.

When removing the rotating base from cavity floor for cleaning, be sure to replace it correctly.

### **DOOR**

Wipe the door and window (both sides), the door seals and adjacent parts frequently with a damp cloth to remove any spills or splatters. Do not use any abrasive cleaners.

While the oven door is still warm, any splatters or food soils should be wiped off with a damp sudsy cloth or sponge. Rinse with water and wipe dry with a cloth. If steam accumulates inside or around the outside of the oven door, wipe it with a soft cloth. This may occur when the microwave oven is operated under high humidity conditions and is normal.

### **EXTERIOR**

#### **CONTROL PANEL**

Exercise care when cleaning this area. Do not allow the control panel to become wet. Clean. When cleaning the control panel, leave the oven door open to prevent the oven from accidentally switching on. To clean, wipe the panel with a slightly dampened cloth, using only water. Wipe dry. Do not scrub this area or use any sort of chemical cleaner. Avoid use of excess water.

#### **OUTSIDE SURFACE**

The outside surfaces should be cleaned with a damp cloth. To prevent damage to the operating parts inside the oven, water should not be allowed to seep into the ventilation slots.

Although your oven is provided with safety features, it is important to observe the following:

When opened, the door must not be subjected to strain, for example, a child hanging on an opened door or any load could cause the oven to fall forward to cause injury and also damage to the door. Do not operate the oven if it is damaged, until it has been repaired by a service technician. It is particularly important that the oven closes properly and that there is no damage to the:

- 1) Door (bent)
- 2) Hinge and latches (broken or loosened)
- 3) Door seals and sealing surface.
- 4) The oven should not be adjusted or repaired by anyone except a properly trained service technician.

If it becomes necessary to replace the oven lamp, consult a Defy Service Centre to have it replaced. Replacement lamps are not covered by the warranty. The oven should be cleaned regularly and any food deposits removed. Failure to maintain the oven in a clean condition could lead to deterioration of the surface that could adversely affect the life of the appliance. It could also constitute a fire risk. Do not dispose this appliance at the local dump. It should be disposed of at a disposal center provided by the municipality.

## GENERAL GUIDELINES

As microwave cooking differs from traditional cooking, the following guidelines should be considered whenever you use your microwave oven

### **If the food is undercooked. Check if:**

- You have selected the correct power level.
- The selected time is sufficient. Selected times depend on initial temperature, weight and density of the food etc.
- The container is appropriate.

### **If the food is overcooked, i.e. dried out or burnt. Check:**

- The power level was too high.
- The set time was too long. Selected times depend on initial temperature, weight and density of food etc.

### **Points to remember when defrosting**

- The shape of the package alters the defrosting time. Shallow rectangular packets defrost more quickly than deep blocks. Separate pieces as they begin to defrost; thin slices defrost more easily.
- Shield areas of food with small pieces of foil if they start to become warm.
- When defrosting, it is better to under thaw the food slightly and allow the process to finish during the standing time.

### **The amount of food**

The more food you want to prepare the longer it takes. A rule of thumb is that double the amount of food requires almost double the time. If one potato takes 4 minutes to cook, two potatoes will take approximately 7 minutes.

### **Starting temperature of food**

The lower the temperature of the food which is being put into the microwave oven, the longer time it takes. Food at room temperature will be reheated more quickly than food at refrigerator temperature.

### **Composition of the food**

Food with a lot of fat and sugar will be heated faster than food containing a lot of water. Fat and sugar will also reach a higher temperature than water in the cooking process. The more dense the food, the longer it takes to heat. "Very dense" food takes a longer time to reheat than lighter, more porous food.

### **Size and shape**

Smaller pieces of food will cook more quickly than larger pieces and uniform pieces of food cook more evenly than irregularly shaped foods. With unevenly shaped food, the thinner parts will cook faster than the thicker areas. Place the thinner chicken wings and legs to the center of the dish.

### **Stirring, turning of foods**

Stirring and turning of foods are techniques used in conventional and well as in microwave cooking to distribute the heat quickly to the center of the dish and avoid overcooking at the outer edges of the food. Covering food helps to reduce spattering, shorten cooking times and retain food moisture. All "microwavable" coverings are suitable.

### **Releasing pressure in foods**

Several foods are tightly covered by a skin or membrane. These foods should be pricked with a fork or cocktail stick to release the pressure and to prevent bursting, as steam builds up within them during cooking. This applies to potatoes, chicken livers, sausages, egg yolks and some fruits.

### **Standing time**

Always allow the food to stand for some time after using the oven. Standing time after defrosting, cooking/ reheating improves the result as the temperature will be more evenly distributed through out the food.

In a microwave oven foods continue to cook even when the microwave energy is turned off. They are no longer cooking by microwaves, but by the conduction of the high residual heat at the center of the food. The length of standing time depends on the volume and density of the food. Sometimes it can be as short as the time it takes you to remove the food from the oven and take it to the serving table. However, with larger, denser foods, the standing time may be as long as 10 minutes. During 'standing', the internal temperature of the food will rise by as much as 8°C and the food will finish cooking in this time.

### **Arranging food**

This is done in several ways in microwave cooking to give more even cooking results. If you are cooking several items of the same food such as jacket potatoes, place them in a ring pattern for uniform cooking. When cooking foods of uneven shapes or thickness, place the smaller or thinner area of the food towards the center of the dish where it will be heated last. Uneven foods such as fish should be arranged in the oven with the tails to the center. If you are saving a meal in the refrigerator or 'plating' a meal for reheating, arrange the thicker, denser foods to the outside of the plate and the thinner or less dense foods in the middle. Place thin slices of meat on top of each other or interlace them. Thicker slices such as meat loaf and sausages have to be placed close to each other. Gravy or sauce should be reheated in a separate container. Use a tall, narrow container rather than a low and wide container. When reheating gravy, sauce or soup, do not fill the container more than 2/3. When cooking or reheating whole fish, score the skin. This prevents cracking. Shield the tail and head with small pieces of foil to prevent over-cooking but ensure the foil does not touch the sides of the oven.

## MICROWAVE RECIPES

### Apricot Chicken

Cooking Time: 22 minutes Serves: 4 people.

#### Ingredients:

Chicken breast fillets, quartered. 750 grams  
Can apricot halves, drained (set juice aside). 410 grams  
Large onion, chopped. 1 large  
Garlic, Crushed. 1 clove(s)  
Butter or Margarine. 30 grams  
(1 tbs) mild curry powder. 15 ml  
Cake Flour. 30 grams  
Salt and pepper to taste  
(1 cup) Apricot Juice. 250 ml

#### Method:

1. Place chicken breast fillets and apricot halves in a casserole dish.
2. Place onion, garlic and butter in a dish, microwave on 100% (full power) for 2 minutes, stir once.
3. Add curry powder and flour, microwave on 100% (high) power for 30 to 40 seconds, stir once.
4. Gradually add juice plus drained syrup from apricots, stir frequently.
5. Microwave on 100% (high) power, three to four minutes or until thickened, stir frequently.
6. Add remaining ingredients and pour over chicken. Microwave covered on 70% (medium-high) power for 12 to 15 minutes or until done. Serves 4 to 6.

### Courgette and carrot muffins

Cooking Time: 9 mins Serves: 15 people

These muffins are excellent lunch-box fillers and an ideal way of getting the kids to eat their veggies.

#### Ingredients:

Self-raising flour, sifted (2 cups). 500 ml  
Bicarbonate of soda (1/2 tsp). 2.5 ml  
Ground cinnamon (1/2 tsp). 2.5 ml  
Ground mixed spice (1 tsp). 5 ml  
Soft brown sugar (1/2 cup). 125 ml  
Finely grated carrots (1 cup). 250 ml  
Finely grated courgettes (1 cup). 250 ml  
Walnuts or pecan nuts, chopped (1 cup). 250 ml  
Eggs, beaten. 2  
Milk (1 cup). 250 ml  
Oil (4 tbs). 60 ml

#### Method:

1. Sift together flour, bicarbonate of soda and spices into a large mixing-bowl.
2. Stir in brown sugar, vegetables and nuts.
3. Beat together eggs, milk and oil, pour into flour mixture, mix well.
4. Spoon into microwave muffin pans, bake six at a time on 100% (high) power, two to three minutes.
5. If using your convection oven preheat oven at 200 degrees and bake for 25 to 30 minutes.
6. Serve warm, halved and buttered.



## MICROWAVE RECIPES

### Easy Whole wheat Loaf

Cooking Time: 17 minutes. An easy step by step method of making your own bread.

#### Helpful Hints:

Sunflower seeds may turn green if used untoasted. To toast, place in flat glass container, microwave on 100% (High) power, 10 minutes per 125ml of seeds or until brown, stirring frequently.

#### Ingredients:

Margarine for greasing  
Sesame seeds or crushed wheat to sprinkle  
(390g) Wholewheat flour. 750 ml  
(150g) Crushed wheat (optional). 250 ml  
Digestive bran. 125 ml  
(45g) Seedless raisins. 60 ml  
(30g) Toasted sunflower seeds. 45 ml  
Salt. 5 ml  
Milk. 500 ml  
Bicarbonate of soda. 10 ml  
Cream of tartar. 15 ml

#### Method:

1. Lightly grease a 130mm x 230mm loaf dish with margarine, line base with paper toweling. Sprinkle sides with sesame seeds or crushed wheat. This gives the bread a lovely texture, you can toast the sesame seeds first to add colour.
2. Combine whole wheat flour, crushed wheat, digestive bran, seedless raisins, sunflower seeds and salt.
3. Mix a little of the milk with bicarbonate of soda, add to rest of milk. Add cream of tartar and honey, blend well.
4. Add milk mixture to flour mixture, stir well until blended.
5. Spoon dough into prepared loaf dish, sprinkle top with sesame and sunflower seeds. Place on an upturned saucer, microwave on 70% (medium-high) power, 17 minutes. Allow to stand 10 minutes. Should you use a different container you may need to adjust timing, so also if your microwave oven is a lower power output.

### Baked Eggs

Cooking Time: 2 minutes.

#### Ingredients

Eggs

#### Method:

1. Break eggs into lightly greased ramekins, dessert bowls or shallow tartlet dishes. Pierce yolks with toothpick or skewer. Cover with clingwrap or a saucer. Microwave on 50% (medium) power, 30 to 60 seconds per egg.
2. Stir egg whites lightly with a fork
3. Microwave on 50% (medium) power, a further 30 to 60 seconds per egg, depending on how hard or soft you like your eggs.

## FREQUENTLY ASKED QUESTIONS

**Q :** I accidentally ran my microwave oven without any food in it. Is it damaged?

**A :** Running the oven empty for a short time will not damage the oven. However, it is not recommended.

**Q :** Can the oven be used with the tray or tray rack removed?

**A :** No. Both the tray and roller guide must always be used in the oven before cooking.

**Q :** Can I open the door when the oven is operating?

**A :** The door can be opened anytime during the cooking operation. Then microwave energy will be instantly switched off and the time setting will maintain until the door is closed.

**Q :** Why do I have moisture in my microwave oven after cooking?

**A :** The moisture on the side of your microwave oven is normal. It is caused by steam from cooking food hitting the cool oven surface.

**Q :** Does microwave energy pass through the viewing screen in the door?

**A :** No. The metal screen bounces back the energy to the oven cavity. The holes are made to allow light to pass through. They do not let microwave energy pass through.

**Q :** Why do eggs sometimes pop?

**A :** When baking or poaching eggs, the yolk may pop due to steam build-up inside the yolk membrane. To prevent this, simply pierce the yolk with a toothpick before cooking. Never cook eggs without piercing their shells.

**Q :** Why this standing time recommended after the cooking operation has been completed?

**A :** Standing time is very important. With microwave cooking, the heat is in the food, not in the oven. Many foods build up enough internal heat to allow the cooking process to continue, even after the food is removed from the oven. Standing time for joints of meat, large vegetables and cakes is to allow the inside to cook completely, without overcooking the outside.

**Q :** What does “standing time” mean?

**A :** “Standing time” means that food should be removed from the oven and covered for additional time to allow it to finish cooking. This frees the oven for other cooking.

**Q :** Why does my oven not always cook as fast as the microwave cooking guide says?

**A :** Check your cooking guide again, to make sure you’ve followed directions exactly; and to see what might cause variations in cooking time. Cooking guide times and heat settings are suggestions, to help prevent over-cooking, the most common problem in getting used to a microwave oven. Variations in the size, shape and weights and dimensions could require longer cooking time. Use your own judgment along with the cooking guide suggestions to check whether the food has been properly cooked just as you would do with a conventional cooker.

**Q :** Will the microwave oven be damaged if it operates while empty?

**A :** Yes. Never run it empty.

**Q :** Can I operate my microwave oven without the turntable or turn the turntable over to hold a large dish?

**A :** No. If you remove or turn over the turntable, you will get poor cooking results. Dishes used in your oven must fit on the turntable.

**Q :** Is it normal for the turntable to turn in either direction?

**A :** Yes. The turntable rotates clockwise or counterclockwise, depending on the rotation of the motor when the cooking cycle begins.

**Q :** Can I pop popcorn in my microwave oven? How do I get the best results?

**A :** Yes. Pop packaged microwave popcorn following manufacture’s guidelines. Do not use regular paper bags. Use the “listening test” by stopping the oven as soon as the popping slows to a “pop” every 1 or 2 seconds. Do not repop unpopped kernels. Do not pop popcorn in glass cookware.

## BRANCHES

If you have followed the instructions and still have a problem, contact the customer care line on 086 100 3339. They will be able to advise you on any aspect of the product or send a qualified technician to repair it.

---

### South African Branches:

#### **BLOEMFONTEIN**

Unit Number 5  
Monument Business Park  
50 Monument Road  
Oranjesig, Bloemfontein  
[Bloemfontein.Service@defy.co.za](mailto:Bloemfontein.Service@defy.co.za)

#### **CAPE TOWN**

5A Marconi Rd. Montague Gardens, 7441  
[CapeTown.Service@defy.co.za](mailto:CapeTown.Service@defy.co.za)

#### **DURBAN**

135 Teakwood Road, Jacobs,  
Durban, 4052  
[Durban.Service@defy.co.za](mailto:Durban.Service@defy.co.za)

#### **EAST LONDON**

Robbie de Lange Road, Wilsonia,  
East London, 5201  
[EastLondon.Service@defy.co.za](mailto:EastLondon.Service@defy.co.za)

#### **GAUTENG, MIDRAND**

127 15th Road, Cnr Pharmaceutical & 15th Rd,  
Midrand, Gauteng  
[Gauteng.Service@defy.co.za](mailto:Gauteng.Service@defy.co.za)

#### **POLOKWANE**

87 Nelson Mandela Drive, Superbia 0699  
[Polokwane.Service@defy.co.za](mailto:Polokwane.Service@defy.co.za)

#### **PORT ELIZABETH**

112 Patterson Road, North End, Port Elizabeth  
6001  
[PortElizabeth.Service@defy.co.za](mailto:PortElizabeth.Service@defy.co.za)

### Sub-Saharan Africa Branches:

#### **ZAMBIA: SOUTHGATE INVESTMENTS LTD**

Plot 1606, Sheki Sheki Road  
P.O. Box 33681  
Lusaka, 10101, Zambia  
Tel: +260 0211 242332/3  
Fax: +260 0211 242933  
[sgiservicecentre@microlink.zm](mailto:sgiservicecentre@microlink.zm)

#### **NAMIBIA: ATLANTIC DISTRIBUTORS (PTY) LTD**

10 Tienie Louw Street, Northern Industrial Area  
P.O. Box 21158, Windhoek, Namibia  
Tel: (061) 216162  
Fax: (061) 216134  
[atlantic@mweb.com.na](mailto:atlantic@mweb.com.na)

#### **ZIMBABWE: TRADECOMAFRICA**

Trade Com Africa, 183 Loreley Crescent  
Msasa, Harare, Zimbabwe  
Tel: +263 4 486165/6  
Cell: +263 772 469010  
Cell: +263 772 469011

#### **BOTSWANA: RAY MORGAN AGENCIES**

RMA Service Centre, Plot 48, East Gate  
Gaborone International Commerce Park  
Kgale View, Gaborone  
Botswana  
Tel: +267 390 3996 / 390 3912  
Fax: +267 318 7376  
Cell: +267 7134 6539  
[service@rma.co.bw](mailto:service@rma.co.bw); [raja@rma.co.bw](mailto:raja@rma.co.bw)

#### **SWAZILAND: LYNDS DISTRIBUTORS**

P.O Box 716, Mbabane, Swaziland, H100  
Tel: (00268) 2515 4310/8  
Fax: (00268) 2518 4318

#### **MOZAMBIQUE: COOL WORLD. LDA**

Rua da Resistencia No. 97B R/C  
Cell: +258 84 44 61 234  
[coolworldlda@hotmail.com](mailto:coolworldlda@hotmail.com)  
Nosso Show Room  
Av: da Industrias, Parcela No.735 \* 735A  
Machava, Maputo

## WARRANTY

- 1 This certificate is issued by DEFY APPLIANCES (PTY) LIMITED manufacturers of Defy and Ocean products, hereinafter the Company, to the original purchaser only, of the appliance described on the certificate and shall constitute the only warranty given in respect of this appliance.
- 2 The Company warrants to the original purchaser that for a period of TWO YEARS from date of purchase the appliance is free from defect under normal domestic use, both in workmanship and material, subject to the following conditions.
- 3 Repair or replacement of any part of this appliance, found by the Company to be defective, shall be at the election of the Company. The Company reserves the right to effect such service through any of its Service Divisions or Authorised Service Dealers.
- 4 **Carry-in service. Microwave ovens are repaired in our service centres and are not collected from the customers home. Faulty units should be delivered to the purchasing dealer or to the nearest Company Service Centre for warranty repairs.**
- 5 Rusted or corroded plates, vitreous enamelware, fuses and lamps are specifically excluded from these warranties. It is an express condition of these warranties that the purchaser takes due care and attention in the use and maintenance of the appliance. Abuse, misuse in conflict with operating instructions, connection to incorrect voltages and subjection to commercial use shall release the Company from its obligations.
- 6 This warranty shall become void and cease to operate if the appliance is dismantled by, or any repairs to the appliance are effected by any persons not duly authorised by the Company, or if substitute parts not approved by the Company are used in the appliance, or if the serial number of the appliance is removed.
- 7 The Company shall not be responsible for damages resulting from fire, flood, civil disturbances or any Act of God. The Company shall not, in terms of these warranties be responsible nor held liable for any consequential loss or damage of any kind caused by or due to the failure or malfunction of the appliance. The Company shall not be responsible for damages caused by insect and/or animal infestation.
- 8 The Company shall not be responsible for transportation or other costs other than those incurred within the provisions of Point 1 of this Certificate.
- 9 **For warranties in the Republic of South Africa and Sub-Saharan Africa, please contact your nearest Defy office. Please refer to the previous page for respective South African branches and Sub-Saharan Africa branches.**
- 10 Where service is requested under warranty and no fault or defect can be found by the Company, all costs incurred will be for the purchaser's account.
- 11 This Certificate as well as your invoice will serve as proof of purchase. For the purpose of warranty, it will be essential to produce this Certificate and invoice. Failure to do so, will render the purchaser liable for service costs.

**KEEP THIS CERTIFICATE AND SALES INVOICE AS PROOF OF  
PURCHASE FOR WARRANTY PURPOSES.**